



2017 Bell 429 Helicopter



Airframe: 240 Hours Total Time

Engines: Total Time: 240 Hours

Highlights: Always Hungared. No Damage. CAMP Tracking

Avionics and Additional Equipment:

NAV/COM/GPS—GTN 750/650 (Garmin)

Chartview Upgrade

ELT—C406-NHM

200 AMP Starter Generator

Increased Capacity Battery

Inlet Barrier Filter

Door Openers Automatic Pax & Crew

Air Conditioning Provisions

Wire Strike Protection Lower Provisions

Wire Strike Protection Upper Provisions

NAV/COM/GPS—GTN 750

NAV/COM/GPS—GTN 750 HTAWS

Radar Altimeter—KRA 405B

Articulated Landing Light

Dual Pilot Controls

Rotor Brake

Corporate Headliner

Bleed Air Heater

Aft Bulkhead Closeout Panel



Interior:

5 Place Corporate Club in Beige Leather with 1 Center Console and Side Arm Rests
3 Point Restraint System

Quick Release Disconnects & ICS Fixed Provisions

Soundproofing /Aft Bulkhead Closeout

Air Conditioner Provisions

Exterior: Black with Silver Accents. Like-New Condition

Exterior Dimensions:

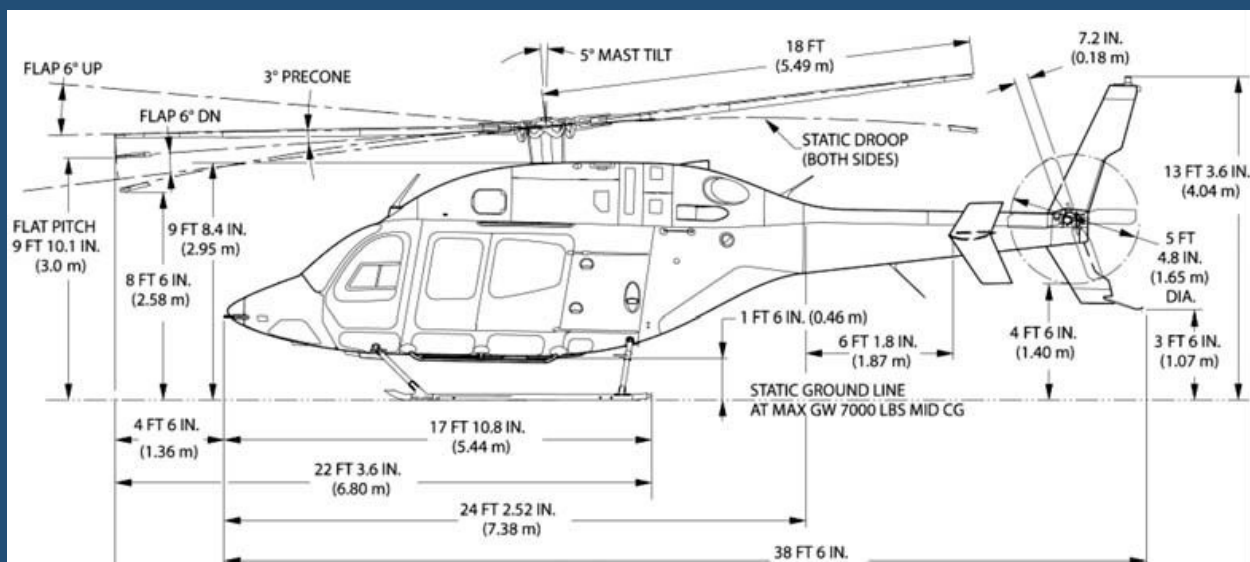
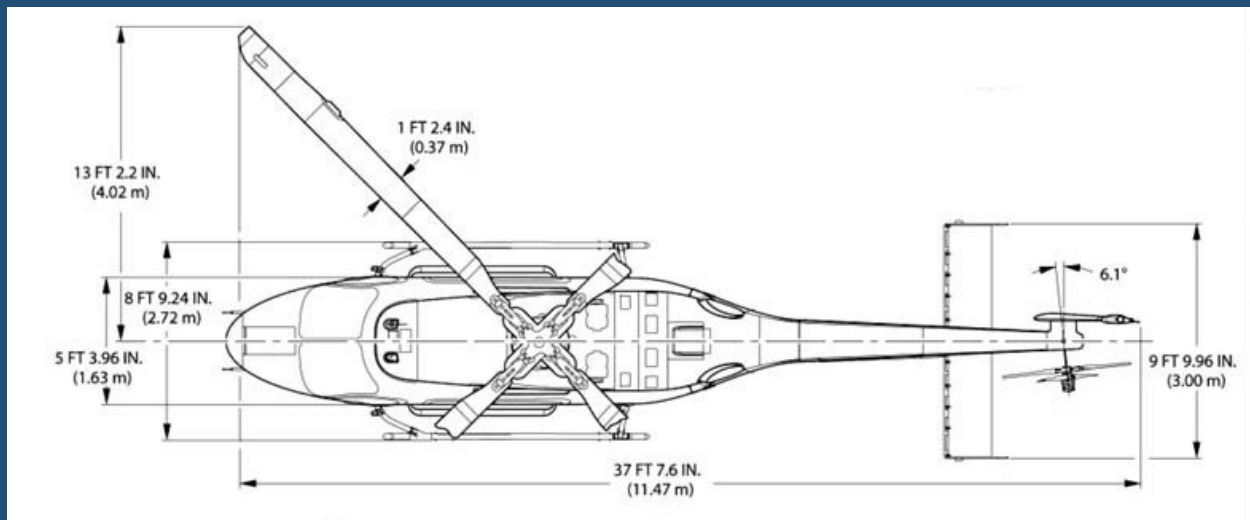

Maintenance Highlights:

CAMP Tracking., D's & MSB's, Always Hangared, No Damage

Specifications subject to verification upon inspection







International Jet Traders
Fort Lauderdale / Savannah
Tel: +1 954 491 1941

www.intljettraders.com
intljettraders@aol.com